

**TRI STAR 6**

**Multi-Purpose Bi-color LED Light**



**Owner's Manual\_v2.1**

## Important Safety Instructions

**There are no user-serviceable components inside the device. The device repair must be done only by qualified specialists.**

**WARNING! To avoid possible malfunctions the device must not be exposed to rain or moisture. Prevent water or other liquids from getting inside the device.**

**WARNING! Do not block the vents or look directly at the LED light while its on.**

### **FCC (Federal Communications Commission)**

This equipment has been tested and found to comply with the limits for class B digital device, pursuant to part 15 of the FCC Rules.

These limits are designed to provide reasonable protection against harmful interface when the equipment is operated in a commercial environment. This equipment generates, uses and can radiate radio frequency energy and if not installed and used in accordance with the instruction manual, may cause harmful interference to radio communications.

**CAUTION: Change or modifications not explicitly approved by the manufacturer could void the user's authority to operate the equipment.**

**RoHS**   

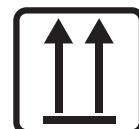

**Made in Taiwan**

## OVERVIEW:

Sturdy, compact, Super-Bright Multi-Purpose SMD LED light with a 3200K (Tungsten) to 5600K (Daylight) color balance making the TRISTAR 6 ideal for use with any camcorder, ENG-style camera or light stand. Together with the dimming control and (detachable) metal barn door system & diffusion filter, this light will always give you the required light output.

## FEATURES:

- 240 long life Super-Bright SMD LEDs
- Robust housing for versatile camera purposes
- Variable dimming control between 3200K – 5600K
- LCD display showing color temperature, brightness & battery capacity
- Two mounting positions & easily mounts on cameras and light stands
- Powered by NP-F, LP-E6, AG-VBR batteries (brackets included) or Mini XLR-4 (D-Tap cable included)

## SPECIFICATIONS:

**Size:** 20.5 x 12 x 5 cm / 8.1 x 4.7 x 2.0 inches

**Weight:** 400 grams / 0.9 lbs

**Color Temp.:** 3200K / 5600K

**Beam Angle:** 120°

**Color Rendering Index:** >90

**LED Life:** approx. 30.000 hrs.

**Power Draw:** approx. 15W

### Power Input:

Battery: Sony NP-F, Canon LP-E6 or Panasonic AG-VBR

Mini XLR-4: 12V DC to 18V DC

## REAR PANEL CONTROLS:

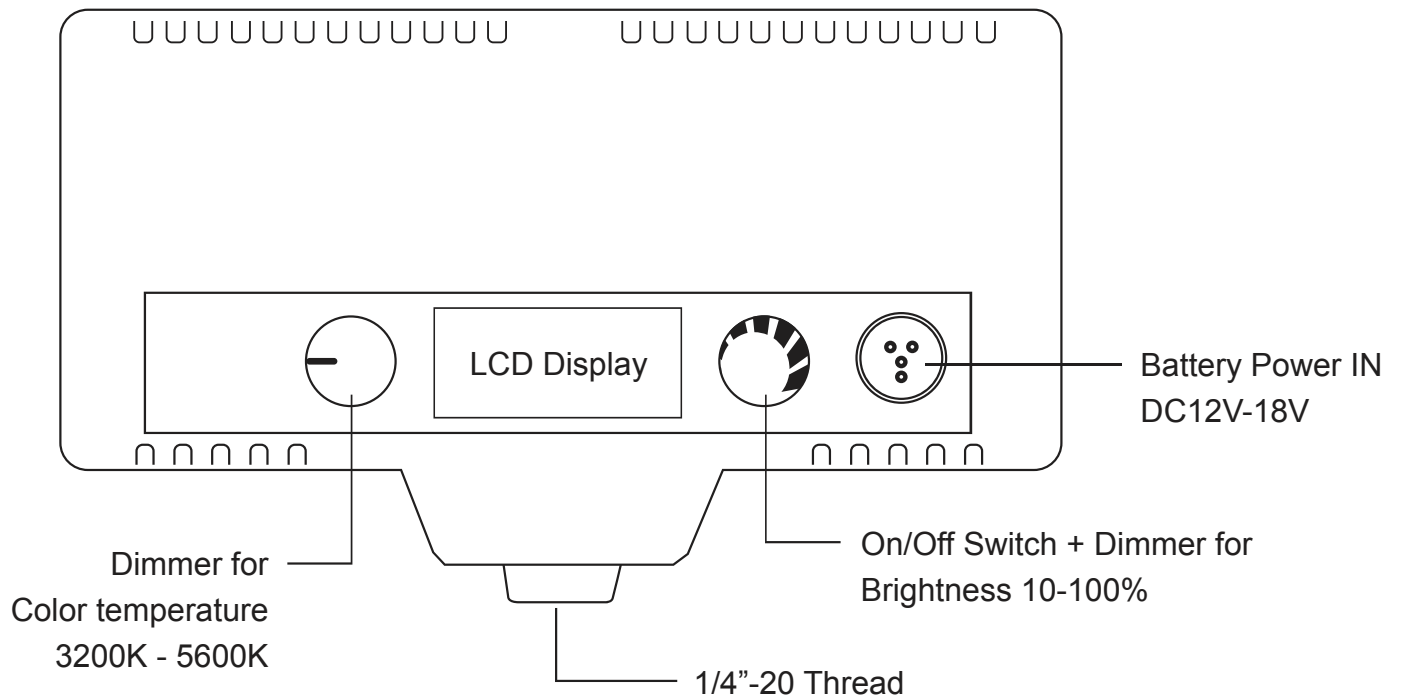

## PHOTOMETRICS:

<b>3200K (Tungsten / Warm white)</b>		
Distance	Footcandles	LUX
0.5m / 1.64 ft.	168	1800
1.0m / 3.28 ft.	46	500
1.5m / 4.92 ft.	27	290
2.0m / 6.56 ft.	17	190

<b>5600K (Daylight / Cool white)</b>		
Distance	Footcandles	LUX
0.5m / 1.64 ft.	181	1950
1.0m / 3.28 ft.	47	510
1.5m / 4.92 ft.	28	300
2.0m / 6.56 ft.	19	200

## INCLUDED IN PACKAGE:

- TRISTAR 6 Super-Bright Multi-Purpose SMD LED light
- Detachable metal barn door system & diffusion filter
- 2 Canon LP-E6 battery brackets
- 2 Panasonic AG-VBR battery brackets
- D-Tap to Mini 4-Pin XLR power cable
- Robust ball head with 1/4" camera screw



## CONDITIONS OF WARRANTY SERVICE:

- Free service for one year from the day of purchase if the problem is caused by manufacturing errors.
- The components and maintenance service fee will be charged if the warranty period has expired.

Free Service will not be provided in the following situations:

(\* Even if the product is still within the warranty period.)

- Damage caused by abuse or misuse, dismantling, or changes to the product not made by the company.
- Damage caused by natural disaster, abnormal voltage, and environmental factors etc.



## WARRANTY REGISTRATION

Dear Customer,

Thank you for purchasing your TRISTAR 6!

We want you to enjoy your purchase to the fullest, and that starts with a few easy warranty registration steps at [www.aspectra.nl](http://www.aspectra.nl)

We advise you to register your TRISTAR 6 before use.

Here's what you need to do:

- 1) Go to [www.aspectra.nl/warranty-registration](http://www.aspectra.nl/warranty-registration) and fill out the warranty registration form. The serial number is located on the outside of the product box and on a sticker in the battery compartment of the physical product.
- 2) Submit the form and receive a confirmation e-mail of your registration.

***Register your product today!***

**Aspectra B.V.**  
**Spoorhaven 78**  
**2651 AV Berkel en Rodenrijs**  
**The Netherlands**  
**[www.aspectra.nl](http://www.aspectra.nl)**